

### Multi-heads feeders for the fabrication of desserts

#### Objectives of the project:

Topping on dessert pots (Ø 70 mm)

- 3 qualities of ingredients: Cocoa, grinded nuts and grated coco
- Powdering of ingredient on a round surface, with no dust on the pot
- 10 simultaneous doses per cycle
- 20 000 dessert pots per hour
- 2 g of ingredient per dessert
- Accuracy requested: +/- 10%
- Dosing time below 1 sec



#### Solution:

- Multi-heads feeder with 10 dosing outputs
- Width: 750 mm
- With the same configuration of the feeder, it is possible to switch to a new ingredient.
- The system, designed according GMP rules, is integrated on a "C" shape movable trolley, to facilitate cleaning operation.
- The feeder is used on different production lines, as the level of dosing heads is adjustable.
- Thanks to pre commissioning by the manufacturer, the feeder was on stream in one day.



# solids *Fine dosing*

The fine art of fine dosing

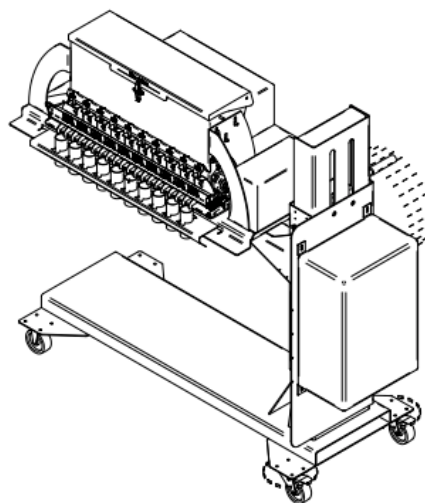
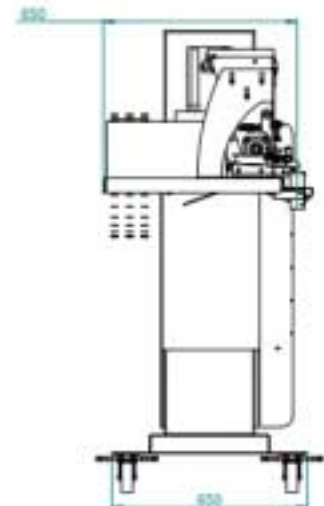
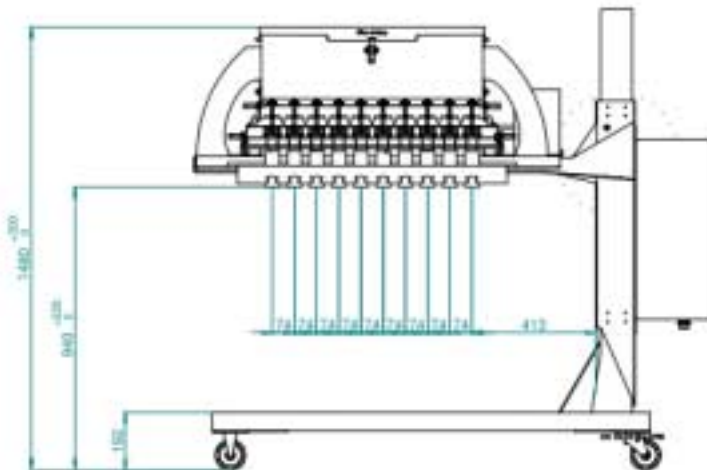

**S.S.T.-Schüttguttechnik Maschinenbau GmbH**  
Lechwiesenstr. 21, 86899 Landsberg / Lech  
Tel. 0049 (0)8191-3359-50 Fax 0049 (0)8191-3359-55  
e-mail: [sst@solids-service.de](mailto:ss@solids-service.de)  
[www.solids.de](http://www.solids.de)

