

solids Vibration Dosing Screw

Type DSV



Safe metering with optimum filling, low-pulsation, high accuracy, no bridging in the inlet area



Advantages:

- **Can be used globally, even for difficult bulk solids**
- **High accuracy and constancy**
- **Suitable for the smallest of volumes**
- **Extendable with weighing**
- **Complete solution with a control unit**
- **Low maintenance**

S.S.T.-Schüttguttechnik Maschinenbau GmbH
Lechwiesenstr. 21, 86899 Landsberg / Lech
Tel. 0049 (0)8191-3359-50 / Fax 0049 (0)8191-3359-55
E-mail SST@solids-service.de www.solids.de



solids Vibration Dosing Screw Type DSV



Characteristics:

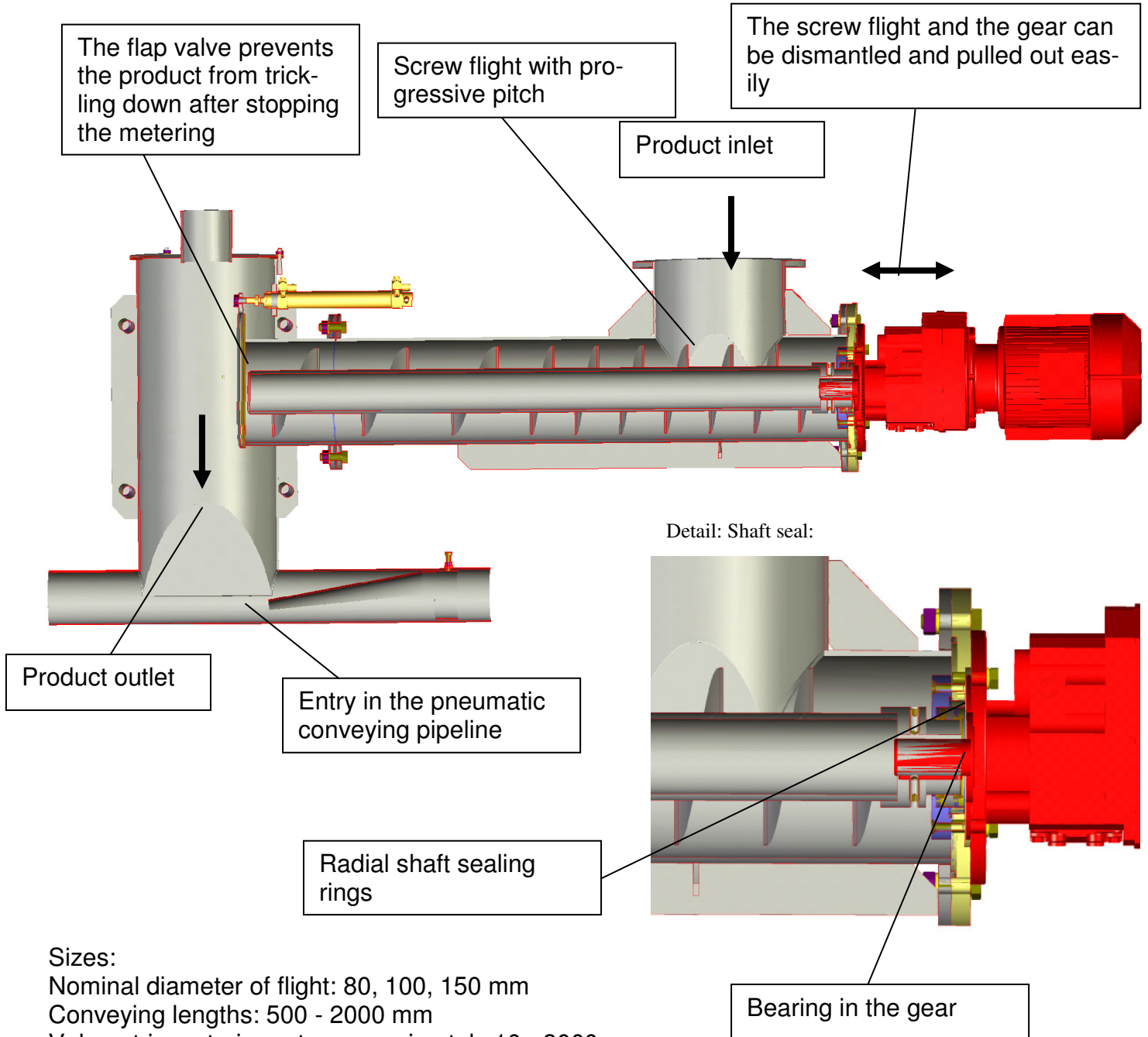

Sizes:
Nominal diameter of flight: 80, 100, 150 mm
Conveying lengths: 500 - 2000 mm
Volumetric metering rate: approximately 10 - 3000 dm³/h

S.S.T.-Schüttguttechnik Maschinenbau GmbH
Lechwiesenstr. 21, 86899 Landsberg / Lech
Tel. 0049 (0)8191-3359-50 / Fax 0049 (0)8191-3359-55
E-mail SST@solids-service.de www.solids.de



solids Vibration Dosing Screw

Type DSV



Discharge from a vessel or a silo, and volumetric or gravimetric metering of bulk solids.

Drums, containers or other casks can be filled.



Advantages:

- **Reliable and universal discharging and metering system**
- **High operational safety due to the sturdy design of components and avoidance of bridging**
- **Quick product change and therefore low cleaning cost**
- **Excellent metering constancy due to the optimum filling of the metering equipment**
- **Low-pulsation metering flow**

S.S.T.-Schüttguttechnik Maschinenbau GmbH
Lechwiesenstr. 21, 86899 Landsberg / Lech
Tel. 0049 (0)8191-3359-50 / Fax 0049 (0)8191-3359-55
E-mail SST@solids-service.de www.solids.de



solids Vibration Dosing Screw

Type DSV



Characteristics of the vibrating cone, type EVS:

- Vibration resistant angular ring design
- Optional for bolting at the vessel
- Nominal diameter 600, 900 or 1200mm
- Flexible suspensions prevent the transmission of vibrations to the supporting structure

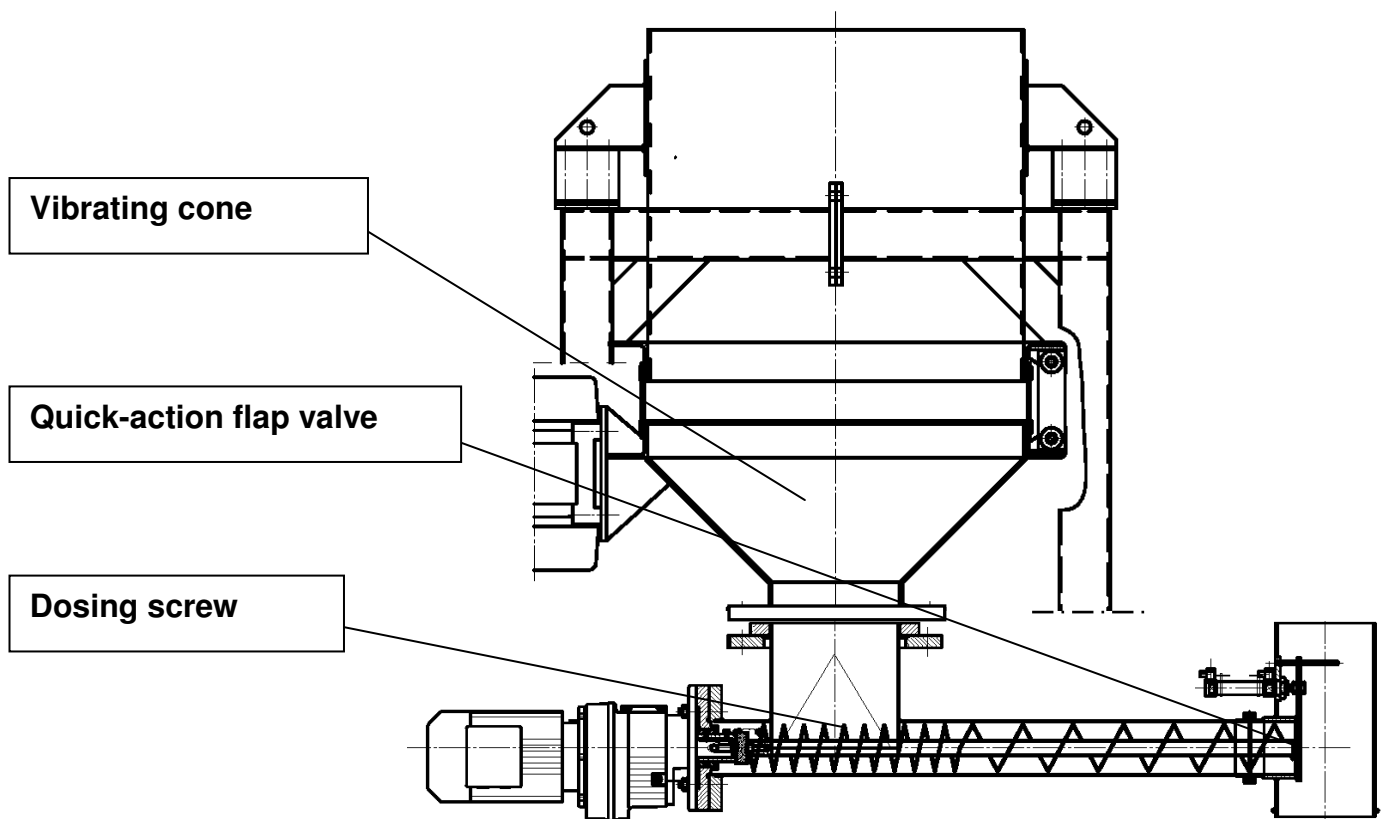

Combination of the vibrating cone type EVS with the vibration metering screw Type DSV:

- Vibrated using a vibrating cone, therefore better filling in the inlet area of the screw, and constant and reliable metering
- Can be dismantled quickly and cleaned easily