

solids Vacuum Batch Conveyor

Type VACUFILL



The complete batch-vacuum conveying system
Alternate filling and emptying of the vacuum batch conveyor; suction under vacuum; complete emptying using compressed air pulse

Reliable technology for safe conveying
of even those products that have poor flowing properties

Functional principle:

Alternate filling and emptying of the vacuum batch conveyor

Sucking the bulk solid under vacuum; batch-wise by the vacuum batch conveyor.

Complete emptying of the vacuum batch conveyor without any pressure or with slight over-pressure.

Your advantages:

- **Gentle product handling and conveying with less wear**
- **Extremely efficient operation due to dense phase conveying**
- **Simple interfaces**
- **Flexible and hence transmission is possible in practically every subsequent system**
- **Dead zone-free design and easy-to-dismantle for quick cleaning**
- **Problem-free use in the ex-zone**
- **Oxygen does not enter the containers when purging with inert gas**
- **Cost-effective solution in case of confined spaces**



S.S.T.-Schüttguttechnik Maschinenbau GmbH
Lechwiesenstr. 21, 86899 Landsberg / Lech
Tel. 0049 (0)8191-3359-50 / Fax 0049 (0)8191-3359-55
E-mail SST@solids-service.de www.solids.de



solids Vacuum Batch Conveyor

Type VACUFILL



Operation sequence:

The vacuum batch conveyor is evacuated using a vacuum pump when the valves for product inlet, emptying and filter dedusting are closed. The vacuum required can be set depending on the product properties and the conveying distance.

The valve of the vacuum pump closed on reaching the set vacuum value.

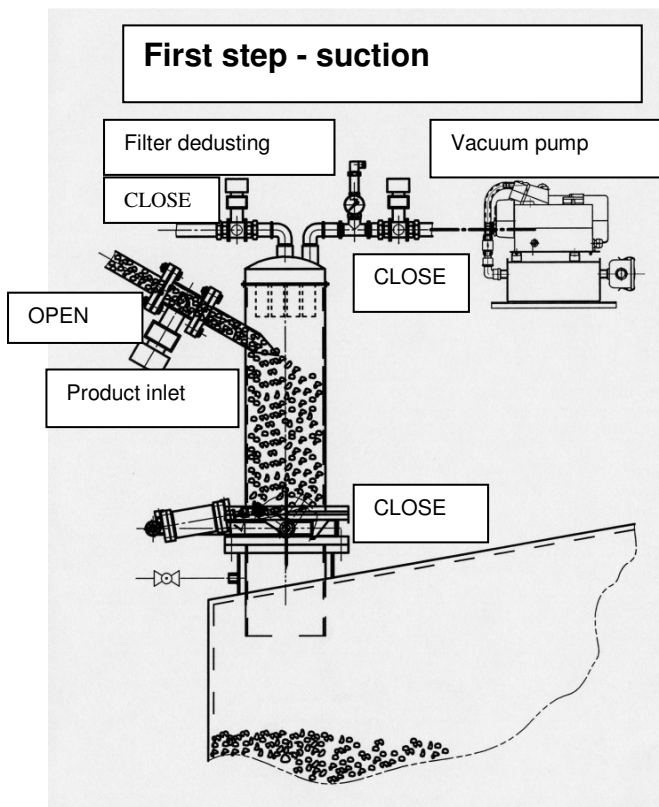

The “product inlet” valve opens for sucking the bulk solid. The generated vacuum now sucks the bulk solid by dense phase into the vacuum batch conveyor.

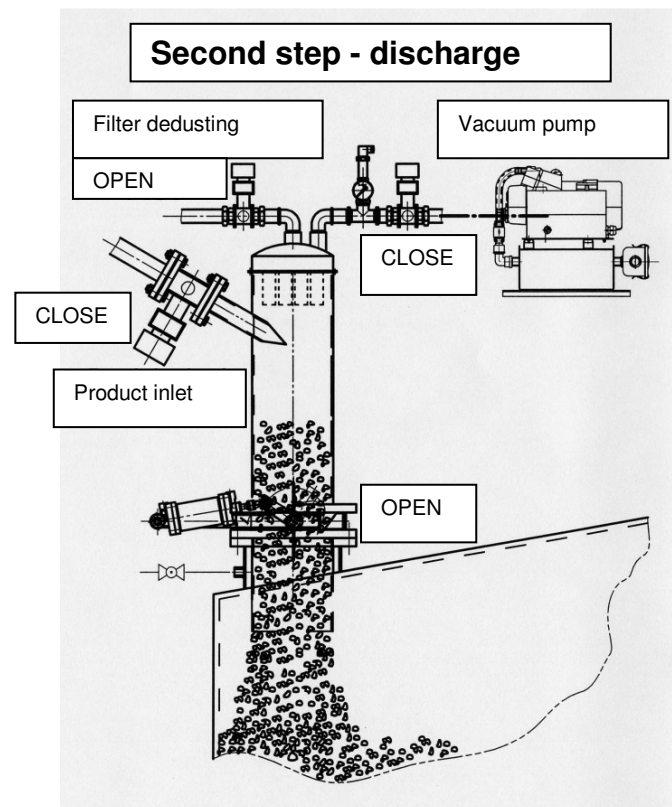

When the vacuum is reduced, the “product inlet” valve closes and the “discharge valve” opens. The discharge process is supported by filter dedusting.

After completing the discharge process, the vacuum batch conveyor is evacuated again, and the sequence is repeated.

