

## **solids Pneumatic Conveyor Type PIP, Industrial / Fine Chemistry / Hygiene Version**



**Pneumatic dense phase conveying by a push conveying process with high load and slow conveying speed for gentle conveying; suitable for sensitive and corrosive bulk solids**

### **Advantages:**

- For granulates, dusts and mixtures
- Slow and gentle conveying with less compressed air and energy consumption
- Simple, cost-effective system assembly
- Less wear and tear due to low speed
- No segregation of mixtures
- Efficient operation even with inert gases
- No angel hair formation in case of plastic granulates
- Small exhaust air filters due to low air volumes
- No particle breakage due to mechanical moving parts
- **Stainless steel construction: Corrosion-resistant due to seamless welding and the use of high-alloyed stainless steels; suitable for foodstuff and chemical/pharmaceutical products due to the design having smooth surfaces and no dead zones; electro-polished at the customer's request or additional surface treatment**



**S.S.T.-Schüttguttechnik Maschinenbau GmbH**  
Lechwiesenstr. 21, 86899 Landsberg / Lech  
Tel. 0049 (0)8191-3359-50 / Fax 0049 (0)8191-3359-55  
E-mail [SST@solids-service.de](mailto:SST@solids-service.de) [www.solids.de](http://www.solids.de)



# solids Pneumatic Conveyor Type PIP, Industrial / Fine Chemistry / Hygiene Version



## Characteristics:

- Complete assembly is TÜV-certified as per the pressure equipment directive 97/23/EC
- Item 1: Material inlet valve and sender seal as a butterfly valve, type DKP-D, pressure-tight
- Item 2: Pressure vessel 40-2500 dm<sup>3</sup>, rated for endurance strength, as per the pressure equipment directive 97/23/EC category IV module G
- Item 3: Welded steel outlet bend
- Item 4: Safety valve 6 bar, as per the pressure equipment directive 97/23/EC
- Item 5: Aeration stick made of porous stainless steel; to be used as a discharge aid
- Item 6: Air exhaust valve as a ball valve; pneumatically actuated, currentless open; approved as per the pressure equipment directive 97/23/EC; for connecting to the air exhaust pipeline
- Item 7: Complete pneumatic installation; for automatic operation, with the TÜV-certified EMSR technique as per the pressure equipment directive 97/23/EC for controlling the conveying cycle and for additional safety from malfunctions and incorrect operation

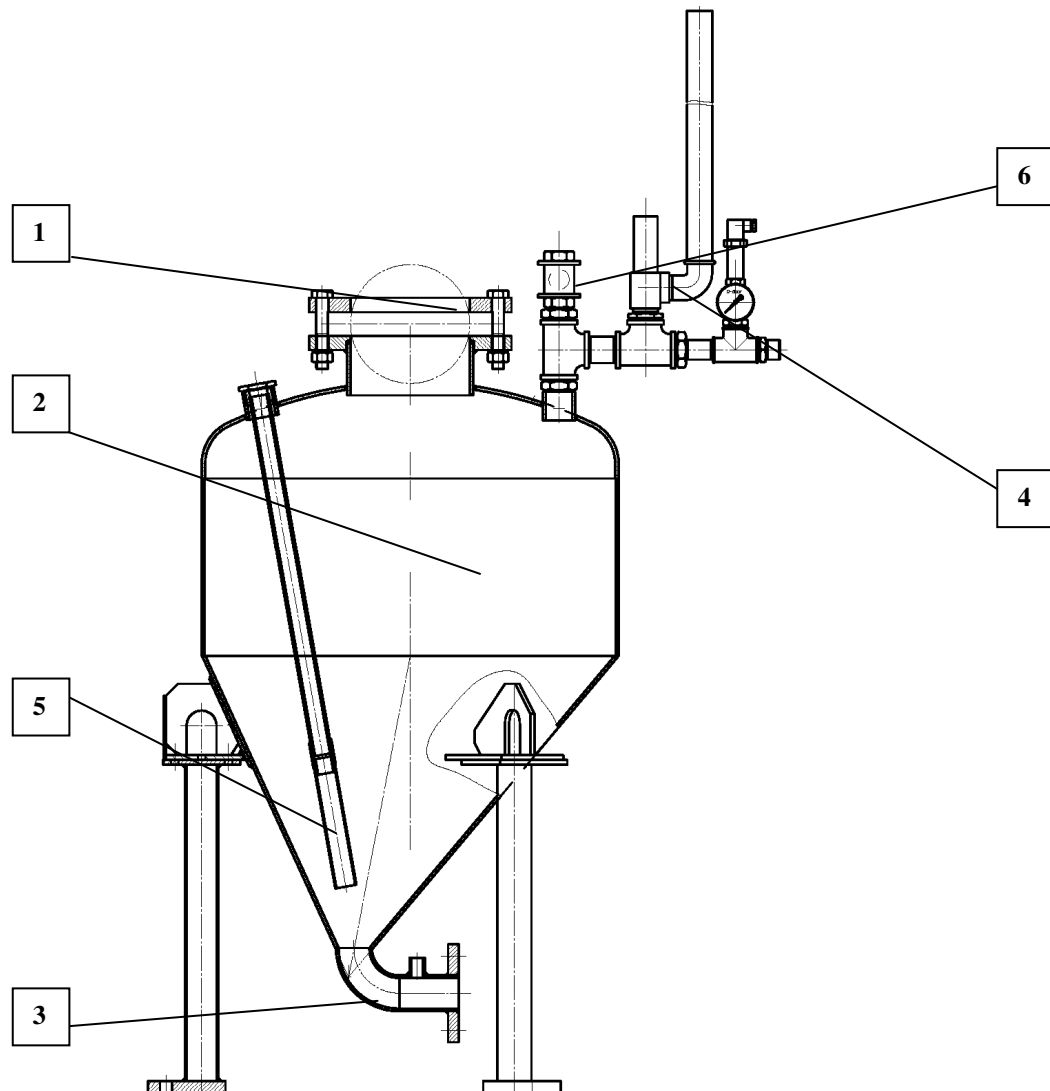

**S.S.T.-Schüttguttechnik Maschinenbau GmbH**  
Lechwiesenstr. 21, 86899 Landsberg / Lech  
Tel. 0049 (0)8191-3359-50 / Fax 0049 (0)8191-3359-55  
E-mail [SST@solids-service.de](mailto:SST@solids-service.de) [www.solids.de](http://www.solids.de)



# solids Pneumatic Conveyor Type PIP, Industrial / Fine Chemistry / Hygiene Version



Pneumatic sender with installation in the cabinet (optional)



**S.S.T.-Schüttguttechnik Maschinenbau GmbH**  
Lechwiesenstr. 21, 86899 Landsberg / Lech  
Tel. 0049 (0)8191-3359-50 / Fax 0049 (0)8191-3359-55  
E-mail [SST@solids-service.de](mailto:SST@solids-service.de) [www.solids.de](http://www.solids.de)



# solids Pneumatic Conveyor Type PIP, Industrial / Fine Chemistry / Hygiene Version

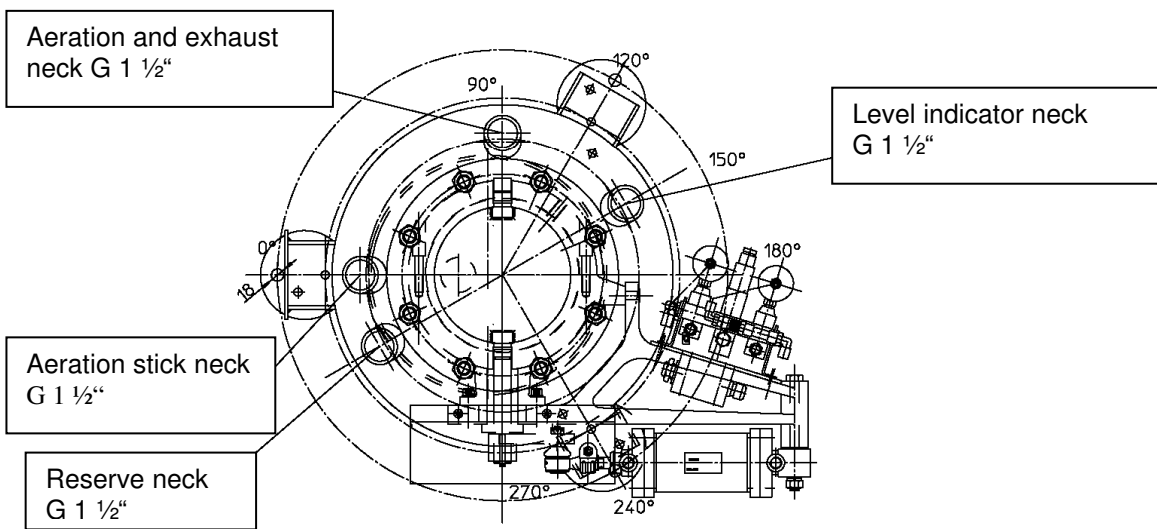
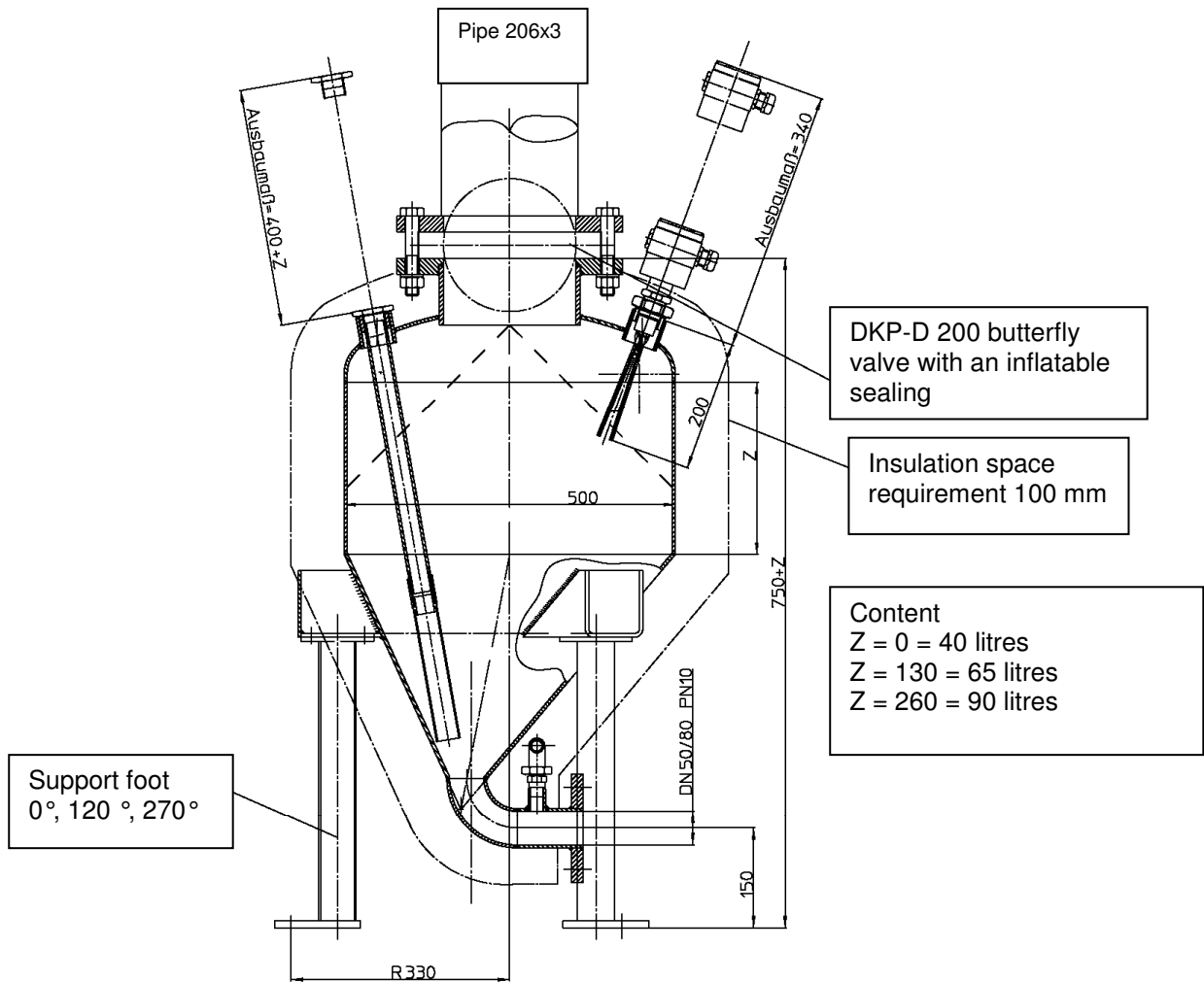

**S.S.T.-Schüttguttechnik Maschinenbau GmbH**  
 Lechwiesenstr. 21, 86899 Landsberg / Lech  
 Tel. 0049 (0)8191-3359-50 / Fax 0049 (0)8191-3359-55  
 E-mail [SST@solids-service.de](mailto:SST@solids-service.de) [www.solids.de](http://www.solids.de)



# solids Pneumatic Conveyor Type PIP, Industrial / Fine Chemistry / Hygiene Version

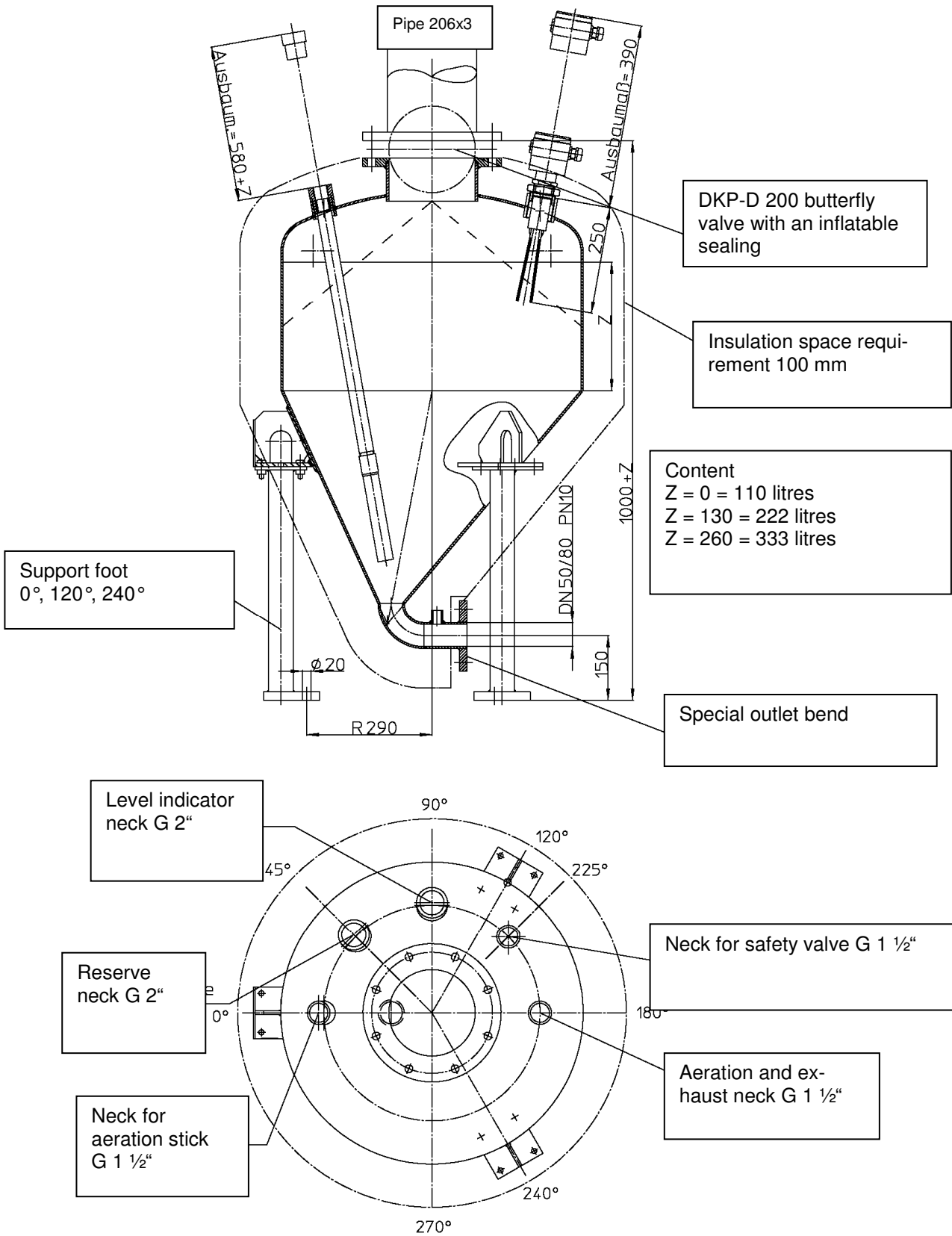

**S.S.T.-Schüttguttechnik Maschinenbau GmbH**  
 Lechwiesenstr. 21, 86899 Landsberg / Lech  
 Tel. 0049 (0)8191-3359-50 / Fax 0049 (0)8191-3359-55  
 E-mail [SST@solids-service.de](mailto:SST@solids-service.de) [www.solids.de](http://www.solids.de)



# solids Pneumatic Conveyor Type PIP, Industrial / Fine Chemistry / Hygiene Version

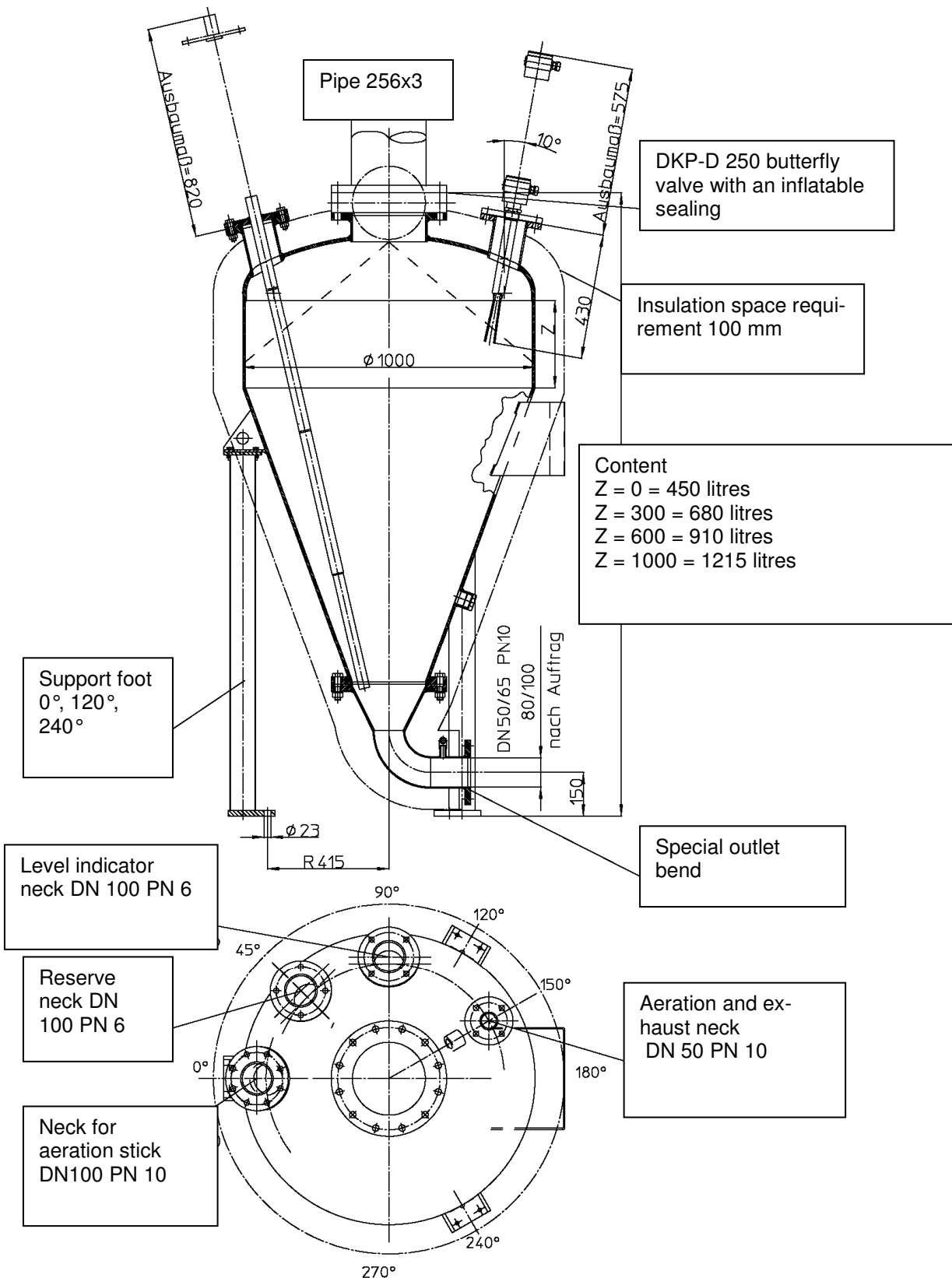

**S.S.T.-Schüttguttechnik Maschinenbau GmbH**  
 Lechwiesenstr. 21, 86899 Landsberg / Lech  
 Tel. 0049 (0)8191-3359-50 / Fax 0049 (0)8191-3359-55  
 E-mail [SST@solids-service.de](mailto:SST@solids-service.de) [www.solids.de](http://www.solids.de)



# solids Pneumatic Conveyor Type PIP, Industrial / Fine Chemistry / Hygiene Version

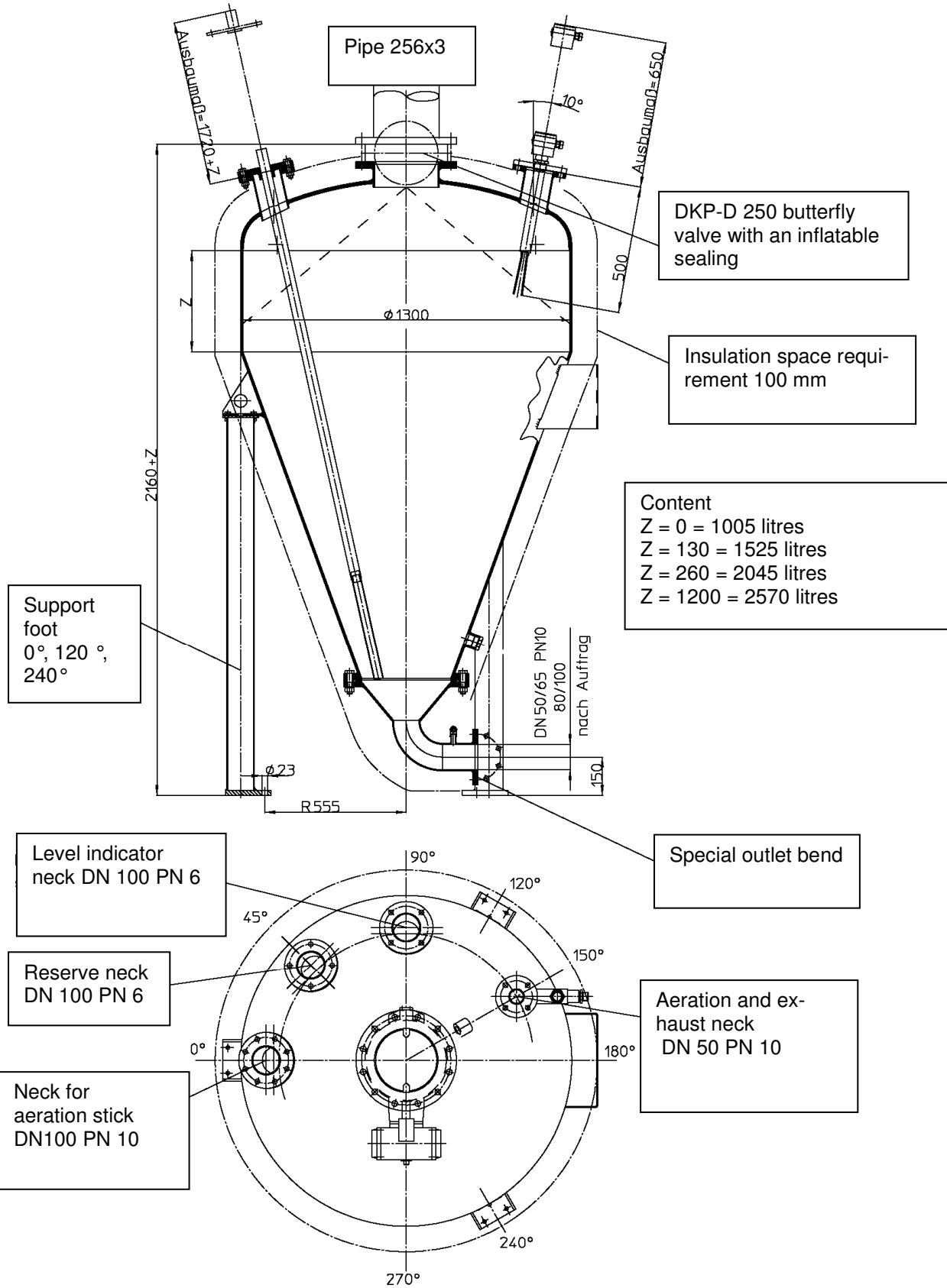

**S.S.T.-Schüttguttechnik Maschinenbau GmbH**  
 Lechwiesenstr. 21, 86899 Landsberg / Lech  
 Tel. 0049 (0)8191-3359-50 / Fax 0049 (0)8191-3359-55  
 E-mail [SST@solids-service.de](mailto:SST@solids-service.de) [www.solids.de](http://www.solids.de)

