

solids Lump Crusher

Fine Crusher, Type K2

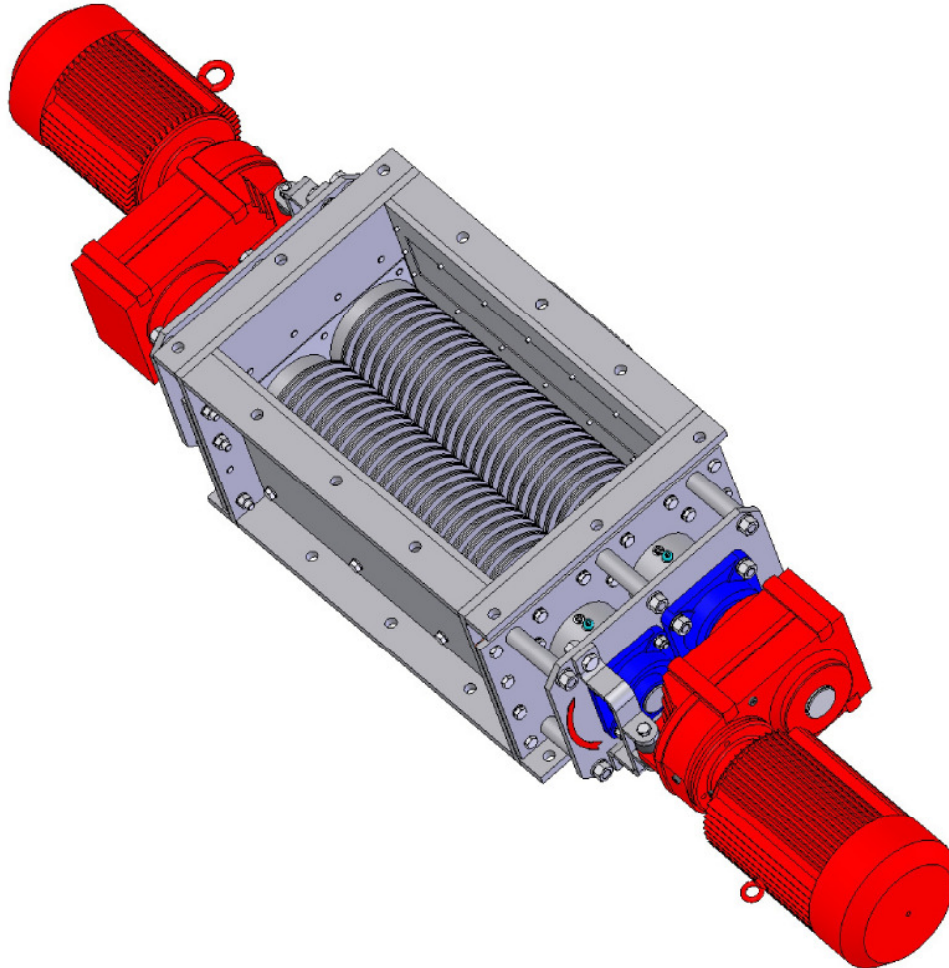

Dual-shaft lump crusher for crushing lumps, clots and crusts in bulk solids



Advantages:

- Low installation cost
- Less installation height
- Sturdy design
- Simple assembly
- Low noise
- Suitable for explosion-hazardous products

S.S.T.-Schüttguttechnik Maschinenbau GmbH
Lechwiesenstr. 21, 86899 Landsberg / Lech
Tel. 0049 (0)8191-3359-50 / Fax 0049 (0)8191-3359-55
E-mail SST@solids-service.de www.solids.de



solids Lump Crusher

Fine Crusher, Type K2

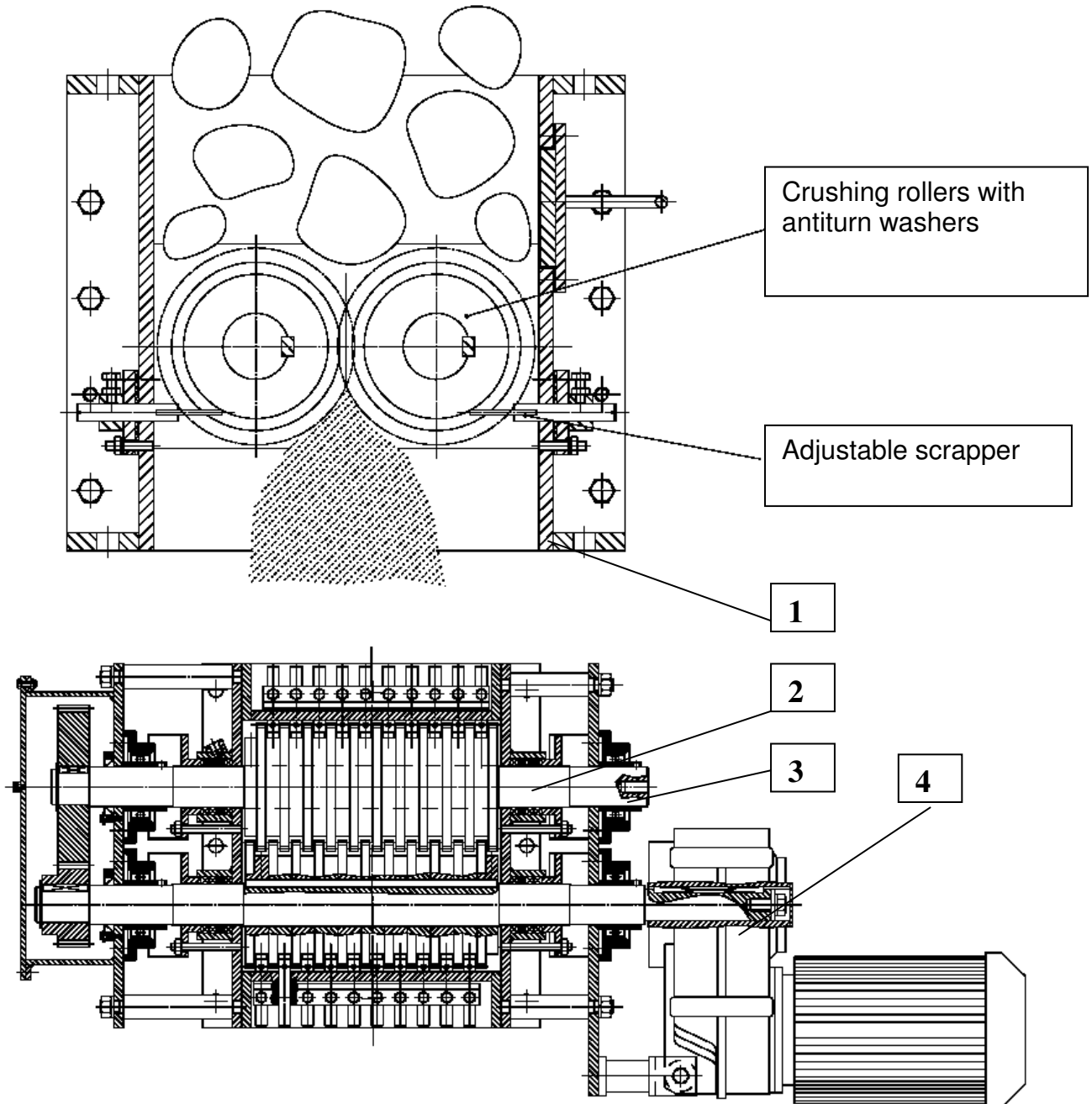

Characteristics:

Sizes: 320x310, 320x480, 320x630 mm or as per customer's specifications

- 1) Sturdy and welded housing
- 2) Shaft feedthrough with packing gland or with special shaft sealing rings for pressure-tight sealing
- 3) External bearing
- 4) Direct drive with a slip-on geared motor

S.S.T.-Schüttguttechnik Maschinenbau GmbH
Lechwiesenstr. 21, 86899 Landsberg / Lech
Tel. 0049 (0)8191-3359-50 / Fax 0049 (0)8191-3359-55
E-mail SST@solids-service.de www.solids.de



solids Lump Crusher
Fine Crusher, Type K2

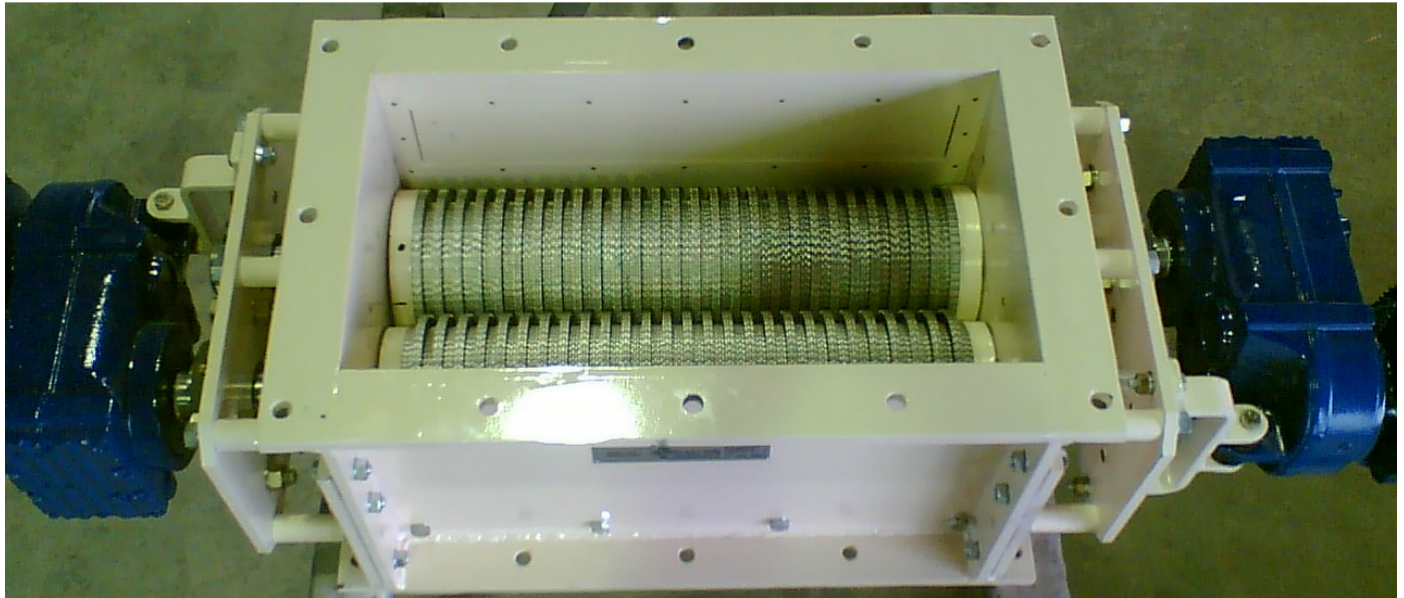

Image: Dual shaft lump crusher with fine tooting and 2 separate drives

S.S.T.-Schüttguttechnik Maschinenbau GmbH
Lechwiesenstr. 21, 86899 Landsberg / Lech
Tel. 0049 (0)8191-3359-50 / Fax 0049 (0)8191-3359-55
E-mail SST@solids-service.de www.solids.de

